

Eco-Tech® 14V, 325A High Amp, Low RPM Alternators Models: J, J-9, P and T-305-1

Product Features and Benefits

- Applications: Fire Trucks, Ambulances, Refuse Collection Trucks, Commercial Fishing and Recreational Boats, Gensets, Construction & Mining, and Vehicles with Telma Braking Systems
- Patented Permanent Magnet Technology
- SAE J-180, Pad and T Mount Configurations
- J-9 a drop-in-replacement for C.E. Neihoff Series 600 alternators
- Factory Adjustable Voltage Set Point
- Remote Battery Voltage Sensing (optional)
- Self Exciting
- Soft Start (Standard)
- Load Dump Protection
- Internally Cooled Using (3) High Efficiency Fans
- 18Month In-Service Warranty
- Exceptionally High Output at Idle and at Low RPM
- High Efficiency Alternator: 80% @ 1,800 rpm
- Extended Brush and Bearing Life



Specifications

Ambient Operating Temperature Range	-40 to +93°C
Rated Current	325 Amperes at 6,000 rpm
Idle Current	260 Amperes at 1,800 rpm
Voltage Set Point	14.4V±0.2V
Efficiency @ 1,800 rpm	80%
Rotation Direction	CW
Maximum Continuous Speed	8,000 rpm
Maximum Intermittent Speed	10,000 rpm
Excitation Type	Self
Ground	Negative
Weight	40 lbs.

Ecoair Corp.

21 Overlook Drive, Hamden, CT 06514-1140
Phone (203) 230-3000, www.ecoair.com, E-mail: info@ecoair.com

"Technology Tuned to Nature"™

Eco-Tech[®] 14V, 325A

High Amp, Low RPM Alternators

Models: J, J-9, P and T-305-I

Output Performance

Stabilized Performance @ 14V, Per SAE J56 Test Specification

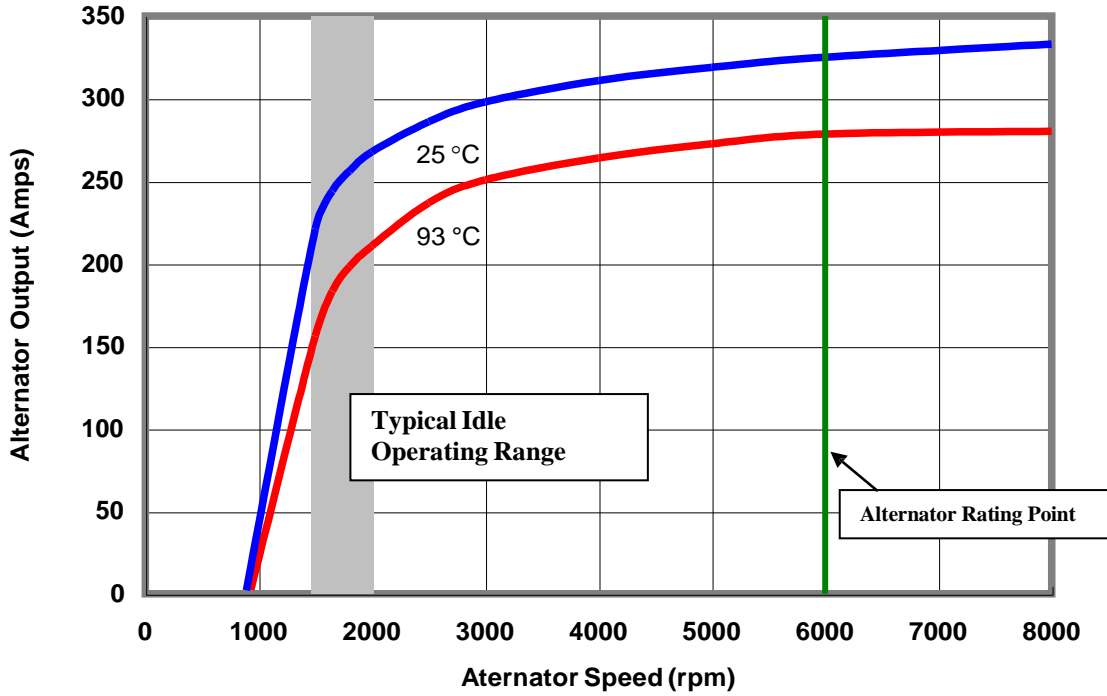

Input Horsepower & Torque at Full Output

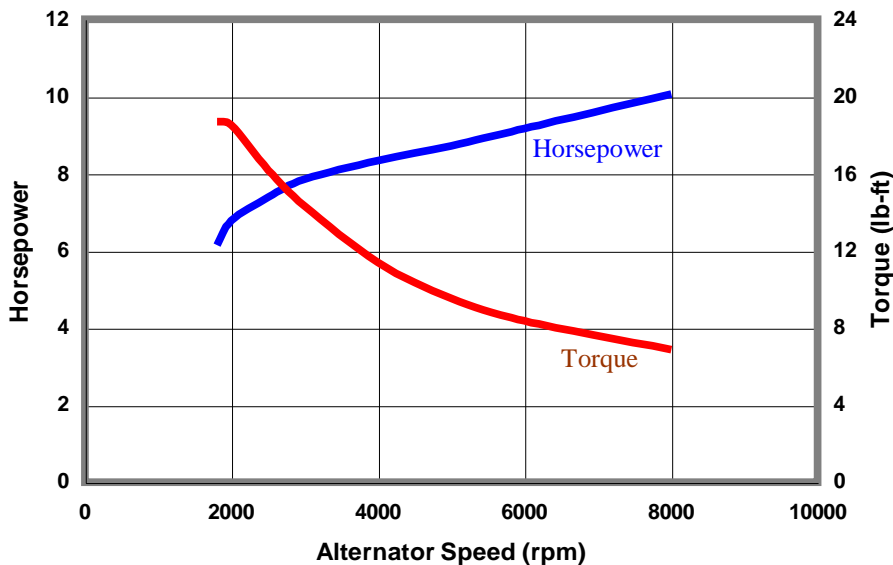

21 CYCLOPS DRIVE, HUNTER, CT 06037-1170
 Phone (203) 230-3000, www.ecoair.com, E-mail: info@ecoair.com

“Technology Tuned to Nature”™

Eco-Tech[®] 14V, 325A

High Amp, Low RPM Alternators

Models: J, J-9, P and T-305-I

Overall Dimensions

J and J9-MOUNT

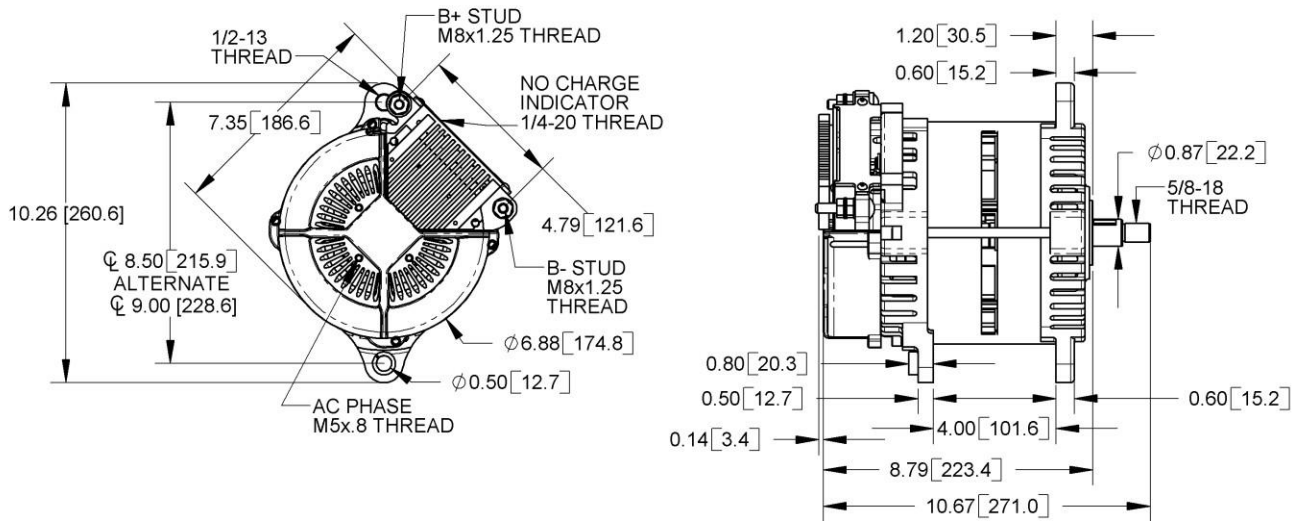
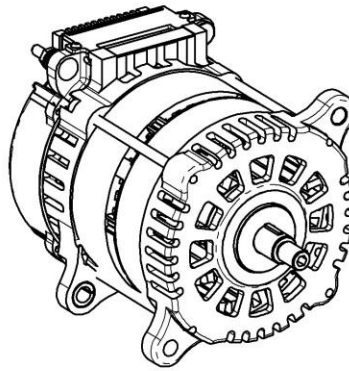

Ecoair Corp.

21 Overlook Drive, Hamden, CT 06514-1140

Phone (203) 230-3000, www.ecoair.com, E-mail: info@ecoair.com

“Technology Tuned to Nature”™

Eco-Tech[®] 14V, 325A

High Amp, Low RPM Alternators

Models: J, J-9, P and T-305-I

Model: P-305-I

Overall Dimensions

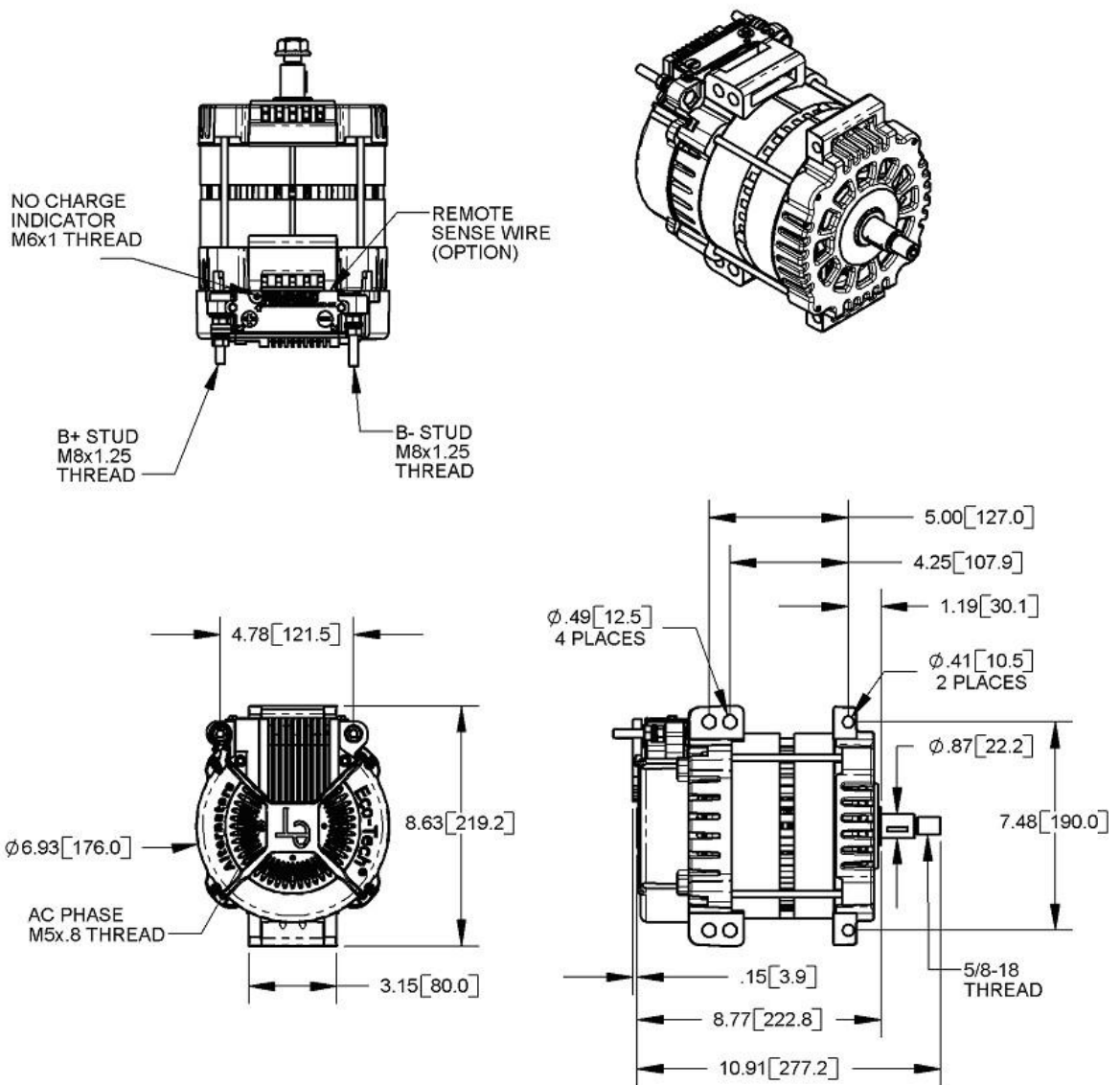

Ecoair Corp.

21 Overlook Drive, Hamden, CT 06514-1140
 Phone (203) 230-3000, www.ecoair.com, E-mail: info@ecoair.com

“Technology Tuned to Nature”™