

Eco-Tech[®] 28V, 165A High Amp Alternators

Models: P-28V/155-I

J-28V/155-I

IJ and IP-28V/155-I (Isolated Ground)

Product Features and Benefits

- **Applications: Commercial Vehicles, Gensets, Marine, Construction & Mining**
- **Patented Permanent Magnet Technology**
- **SAE J-180 and Pad Mounting Configurations**
- **Ignition Protected (Model IJ-28V/155-IP-C): Conforms to SAE J1171, ISO 8846 and USCG Title 33 CFR 183.410**
- **Isolated Ground (Models IJ-28V/155-I, IJ-28V/155-IP-C)**
- **Adjustable Voltage Set Point**
- **Remote Battery Voltage Sensing (optional)**
- **Self Exciting**
- **Soft Start (Standard)**
- **Load Dump Protection**
- **Internally Cooled Using (3) Highly Efficient Fans**
- **18 Month In-Service Warranty**
- **Exceptionally High Output at Idle and at Low RPM**
- **High Efficiency Alternator: 80% @ 1,800 rpm**
- **Extended Brush and Bearing Life**



Specifications

| | |
|-------------------------------------|--------------------------|
| Ambient Operating Temperature Range | -40 to +93°C |
| Rated Current | 165 Amperes at 6,000 rpm |
| Idle Current | 127 Amperes at 1,800 rpm |
| Voltage Set Point | 28.2 V ± 0.4 V |
| Efficiency @ 1,800 rpm | 80% |
| Rotation Direction | CW |
| Maximum Continuous Speed | 8,000 rpm |
| Maximum Intermittent Speed | 10,000 rpm |
| Excitation Type | Self |
| Ground | Negative |
| Weight | 40 lbs. |

Ecoair Corp.

21 Overlook Drive, Hamden, CT 06514-1140
Phone (203) 230-3000, www.ecoair.com, E-mail: info@ecoair.com

“Technology Tuned to Nature”™

Eco-Tech[®] 28V, 165A High Amp Alternators

Models: P-28V/155-I
J-28V/155-I

IJ and IP-28V/155-I (Isolated Ground)

Output Performance

Stabilized Performance @ 28V, Per SAE J56 Test Specification

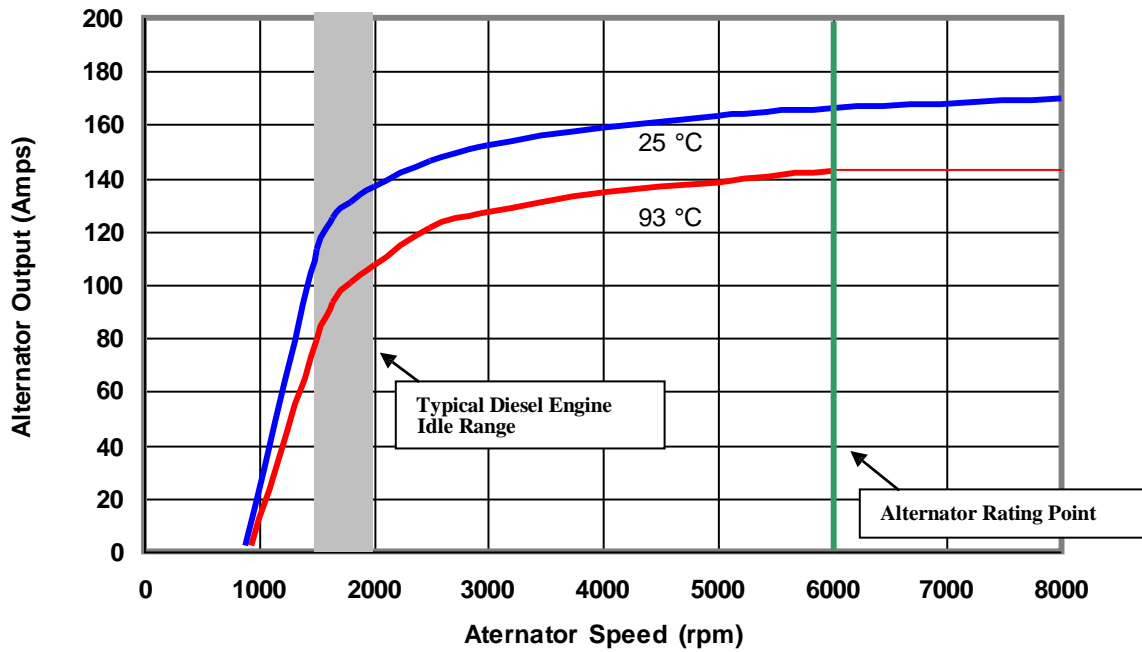

Input Horsepower & Torque at Full Output

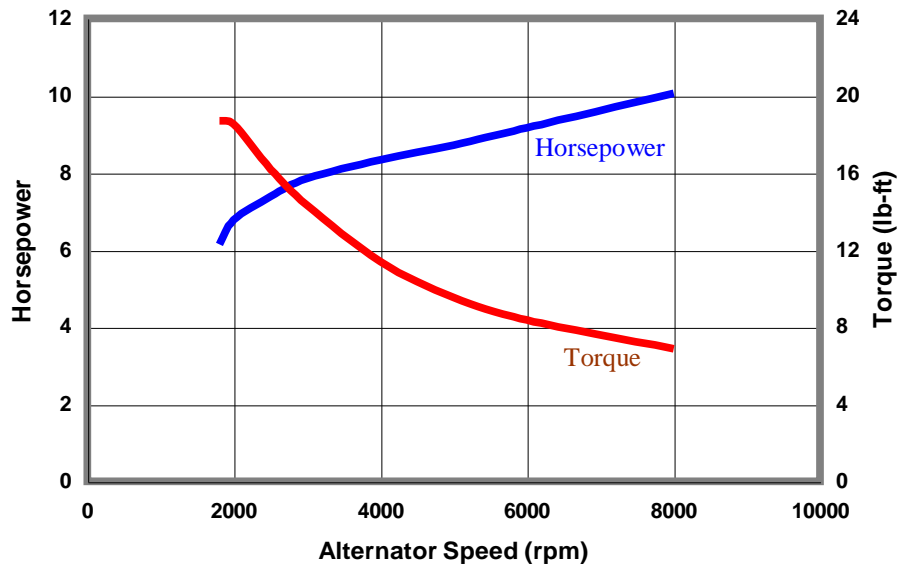

Eco-Tech® 28V, 165A High Amp Alternators

Models: P-28V/155-I

J-28V/155-I

IJ and IP-28V/155-I (Isolated Ground)

Overall Dimensions

Models: P-28V/155-I and IP-28V/155-I

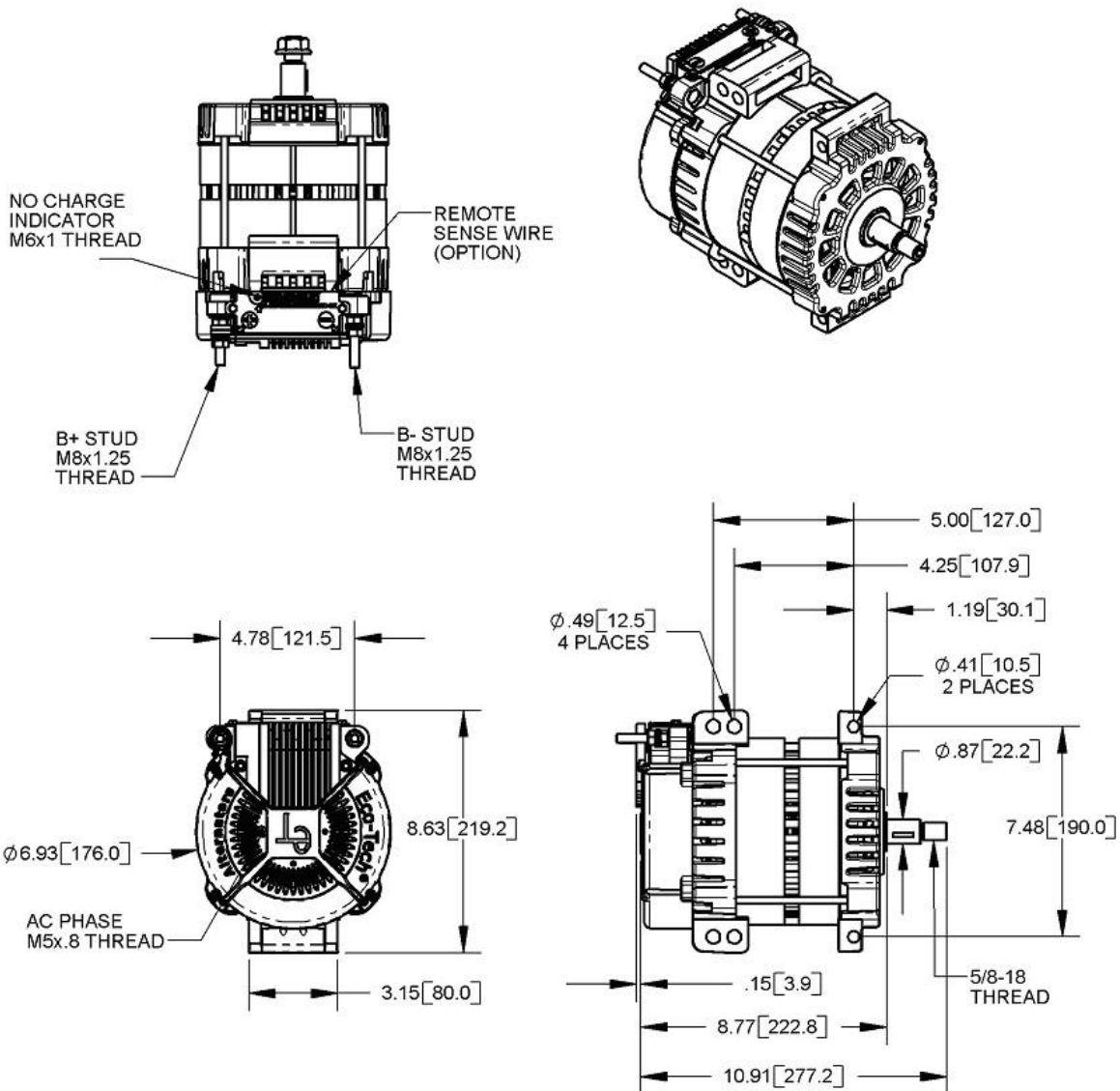

Ecoair Corp.

21 Overlook Drive, Hamden, CT 06514-1140

Phone (203) 230-3000, www.ecoair.com, E-mail: info@ecoair.com

“Technology Tuned to Nature”™

Eco-Tech[®] 28V, 165A High Amp Alternators

Models: P-28V/155-I

J-28V/155-I

IJ and IP-28V/155-I (Isolated Ground)

Overall Dimensions

Models: J-28V/155-I and IJ-28V/155-I

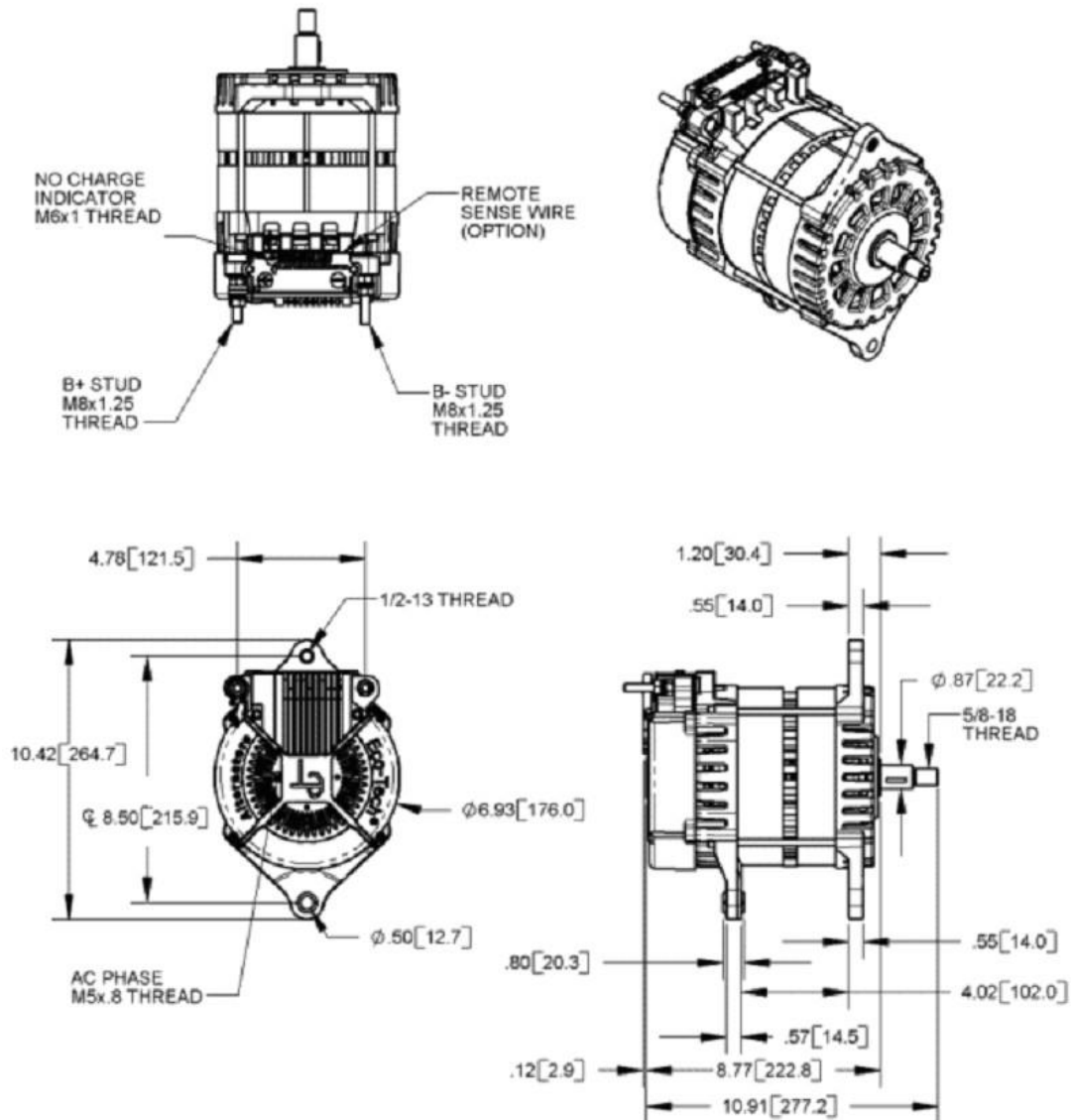

Ecoair Corp.

21 Overlook Drive, Hamden, CT 06514-1140

Phone (203) 230-3000, www.ecoair.com, E-mail: info@ecoair.com

“Technology Tuned to Nature”™